

## Optical Transmittance Analyzer SL MA-100

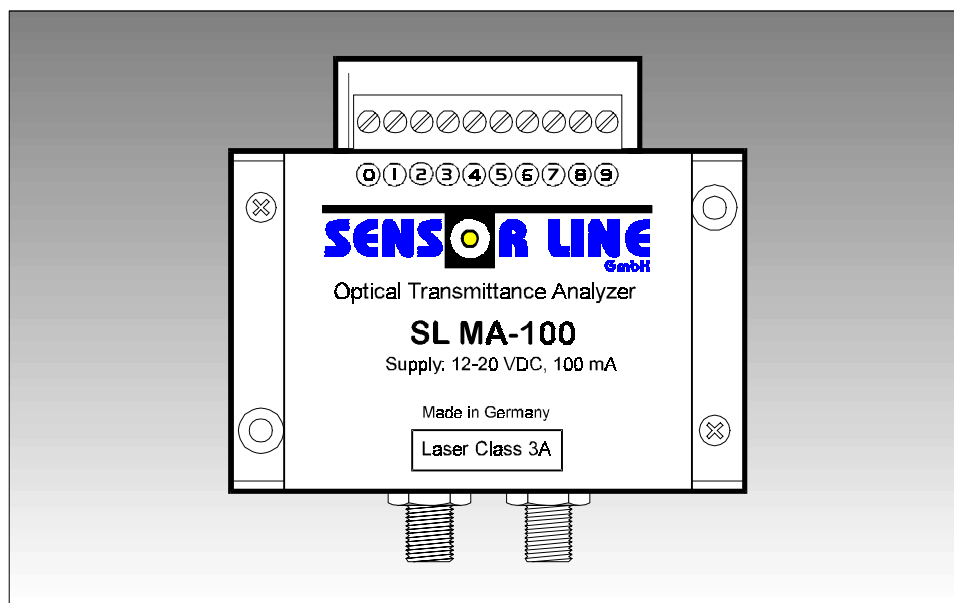

# ***USER'S MANUAL***

## Attention

© Copyright 1997 by Sensor Line GmbH  
In der Scherau 1  
D-86529 Schrobenhausen

All the information contained herein is believed to be accurate and reliable. However, SENSOR LINE assumes no responsibility for its use or for any infringements of patents or other rights of third parties that may result from its use. No license is granted by implication or otherwise under any patent rights of SENSOR LINE GmbH.

SENSOR LINE GMBH SHALL NOT BE LIABLE FOR ANY SPECIAL, INCIDENTAL, OR CONSEQUENTIAL DAMAGES RELATED TO THE USE OF THIS PRODUCT.

All rights reserved. Reproduction or adaptation of any part of this documentation beyond without permission of the Copyright owner is unlawful.

# Table of Contents

- 1. General information..... 4**
- 2. Connections..... 5**
- 3. Signals..... 5**
  - 3.1. The Analog Load Signal..... 5
  - 3.2. The Analog Monitor Signal..... 5
  - 3.3. The Digital Trigger Signal ..... 6
  - 3.4. The Digital Error Signal..... 7
- 4. Fitting and starting..... 7**
- 5. Specifications..... 8**
- 6. Safety & Warnings..... 8**

## 1. General information

The optical transmittance analyzer SL MA-100 is an electronic interface for supplying and evaluating optical load sensors. It is developed as an interface between sensor and processing unit to be operated in indoor areas. It can also be installed outdoors in a weatherproof road side cabinet. A typical installation consists of the interface with transmitter (LED) and receiver (photodetector) connected with light guide feeder cable and one fiber optic load sensor embedded in the road surface.

### Functions:

The interface responds to the optical sensor signal in a dynamic (AC-coupled) manner i.e. the electronic signal caused by a load applied to the sensor decreases to zero as the load remains being applied. On excess of a certain threshold a digital trigger signal is generated which is also automatically reset after a certain time. This behaviour allows the interface to be put into operation and to operate without the need of any adjustment.

If the light transmission path is interrupted this is detected by the interface and indicated by generation of an additional digital output signal. Both digital signals are transmitted via optocouplers which behave similar to relais and allow to use a variety of output circuitry. The dynamic analog load signal as well as a light power monitor signal are available at their own output clips.

### Features:

- Dynamic interface for detection of light power changes
- Optocoupler digital outputs
- Trigger output (optocoupler)
- Error indication output
- Analog output
- Monitor output for normalizing the analog signal
- Reverse power protection
- Short circuit protection
- Housing 67x58x25mm IP 30
- 10-pin screw clip

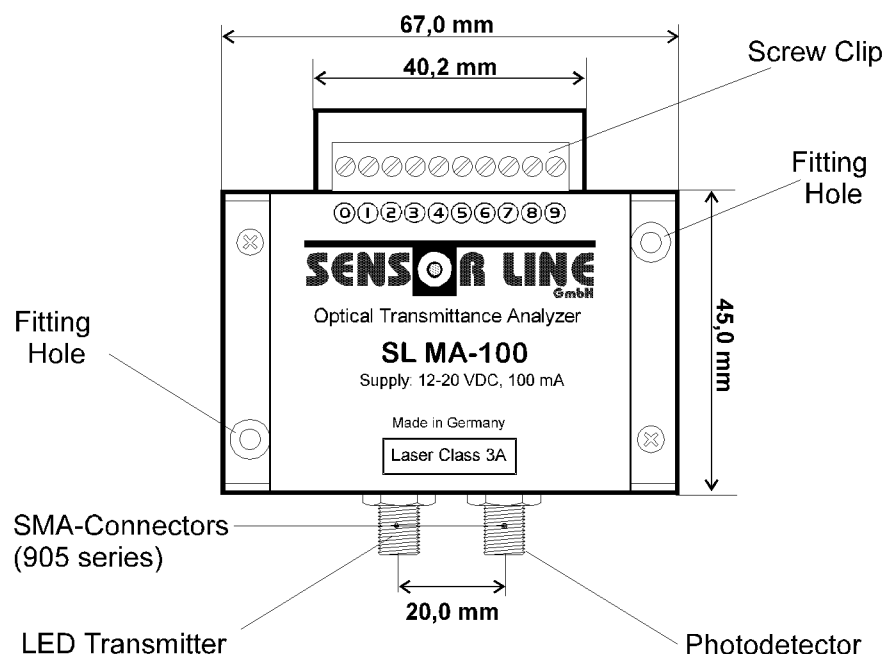

## 2. Connections

### *Electrical*

Pin No	Sign	Description
0	12 ... 20 VDC	Supply Voltage
1	GND	Ground
2	GND	Ground
3	Vref	Reference Voltage (about 5 V)
4	Vmon	Analog Monitor Signal
5	Vanalog	Analog Load Signal
6	-ERROR	Negative Error Optocoupler Output
7	+ERROR	Positive Error Optocoupler Output
8	-TRIGGER	Negative Trigger Optocoupler Output
9	+TRIGGER	Positive Trigger Optocoupler Output

### *Optical*

**SMA-Connectors**  
(SMA series 905)

LED Transmitter, Photodetector

## 3. Signals

### 3.1. The Analog Load Signal

This signal shows the light changes which occur due to the load applied on the sensor in an "AC-coupled" manner.

To obtain the load signal connect Vanalog (pin 5) and Vref (pin 3) to a measuring device. Either use Vref as reference voltage or measure both Vanalog and Vref with reference to GND (Pin 2). In this case do the computation

$$\text{Load Signal} = \text{Vanalog} - \text{Vref}$$

### 3.2. The Analog Monitor Signal

In case the load signal is zero this signal shows the absolute light power transmitted by the sensor. It is obtained as is the load signal but it is negative with reference to Vref.

$$\text{Monitor Signal} = -(\text{Vmon} - \text{Vref})$$

As the light changes caused by the load are much smaller than the whole light power the monitor voltage is amplified by a factor of 20 less than the load signal. In either case the complete transmitted light power is proportional to the value

$$\text{Monitor Signal} - \text{Load Signal} / 20$$

To obtain a normalized load signal independent from the particular sensor's attenuation, do the computation

$$\text{Normalized Load Signal} = 5 \times \frac{\text{Load Signal}}{\text{Monitor Signal}} \text{ in \%}$$

### 3.3. The Digital Trigger Signal

As the trigger signal is transmitted via an optocoupler one of the following circuits is required ( $V_{\text{supply}}$  may be any external power supply).

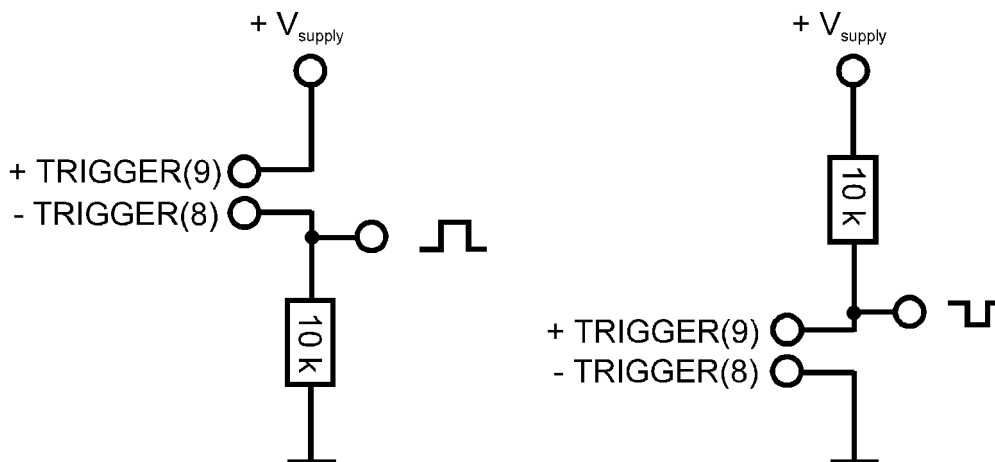

The left circuit yields a positive trigger pulse, the circuit on the right side an inverted one.

The waveforms below show the signals caused by a vehicle crossing the sensor:

Upper graph:  $V_{\text{analog}}$  (pin 5) related to  $V_{\text{ref}}$  (pin 2)

Lower graph: Signal occurring at  $-$ TRIGGER (pin 8) with  $+$ TRIGGER (pin 9) connected to +15V and a 10k pull down resistor from  $-$ TRIGGER to GND (pin 1, pin 2).

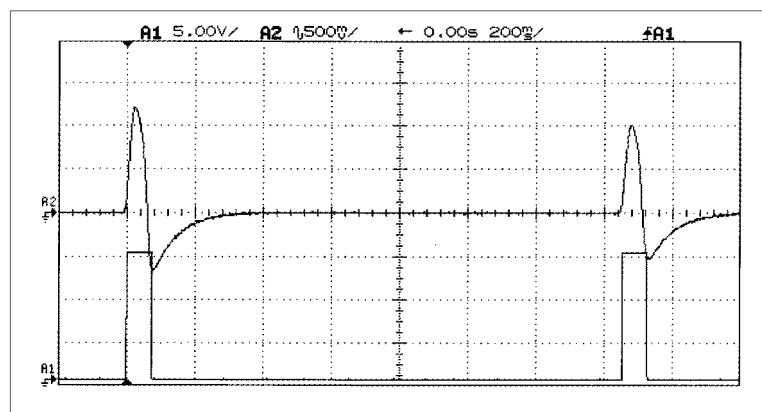

### 3.4. The Digital Error Signal

To obtain the Error Signal also one of the circuits on the previous page can be used.

If an Error signal occurs first check the monitor signal as described under 3.2. If this equals to zero the transmission path is interrupted. In case it is below 250 mV the attenuation of the transmission path exceeds the limit specified for proper operation of the triggering circuit. This should not occur because the sensors are tested for attenuation. The interface may then still work, but in certain cases the trigger signal may not be reset when the load is removed from the sensor. Try cleaning the fiber connectors with a soft cloth. Be sure that neither the sensors nor the feeders are bent over sharp edges. If this doesn't help the sensor or the feeders might be damaged and should be replaced.

## 4. Fitting and starting

- 1) Fit the interface with screws.
- 2) Remove the safety caps from LED transmitter and photodetector.
- 3) Connect the sensor SMA connectors with transmitter and photodetector.

When fastening the sensor SMA connectors with transmitter and photodetector a strong torque must be applied in order to guarantee smallest attenuation, but do not use any pliers . The connectors of transmitter and photodetector are allowed to be interchanged.

- 4) Connect the pins 0 (Supply Voltage) and 1 (Ground) to the power supply.
- 5) Connect the signal outputs (pin 2 to 9)
- 6) Turn on power supply
- 7) Test the installation by overrolling the embedded sensor and monitoring the Trigger signal (pin 8 and 9) or Vanalog signal (pin 5).  
Test the sensor Error signal (pin 6 and 7) by disconnecting one of the fiber connectors.

## 5. Specifications

Supply Voltage:	+12 to +20 VDC
Supply Current (continuous):	< 100mA
Analog Output:	0 - 10V
Analog Output Impedance:	1k $\Omega$
Trigger Threshold:	1% of light transmittance change
Sensor Attenuation:	3 - 13 dB
Max. Strain Optocouplers:	60V/25mA
Velocity Range:	1 to 250 km/h
Feeder Length:	up to 250 meters
Laser Class:	3A
EMV/EMI:	fulfils CE-requirements

## 6. Safety and Warnings

- Do not stare into the LED light beam with unprotected eyes.
- Only turn on power supply after connecting the sensor or with applied safety caps.
- The equipment may only be used for the considered purpose.
- The manual should be stored at hand and be delivered to every user.
- Any changes and the use of spares which are not sold by the manufacturer cause rejects of warranty.
- Repairs are only allowed to the manufacturer.
- Before opening the housing always turn off power supply.



**Sensor Line - Gesellschaft für  
optoelektronische Sensoren mbH  
In der Scherau 1  
D-86529 Schrobenhausen / Germany  
Tel: +49 / (0) 8252 / 8943-0  
Fax: +49 / (0) 8252 / 8943-11  
eMail: [sensorline@sensorline.de](mailto:sensorline@sensorline.de)  
HP: [www.sensorline.de](http://www.sensorline.de)**