

Optical Transmittance Analyzer

SL MA-310

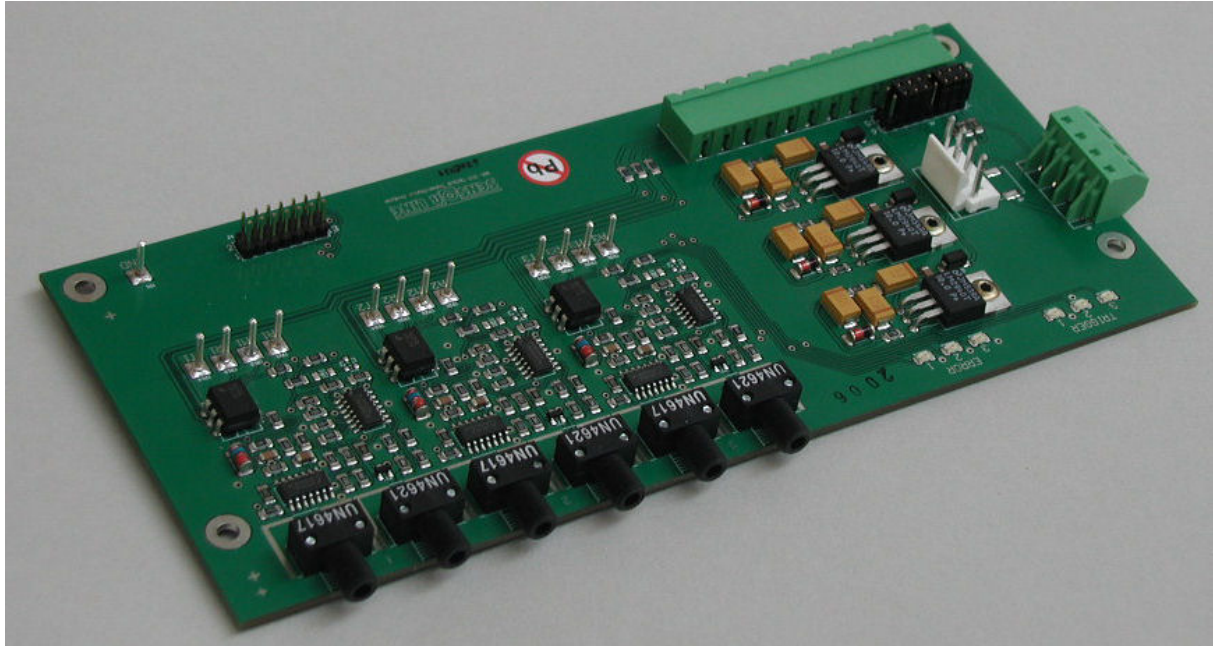

User's Manual



Sensor Line - Gesellschaft für
optoelektronische Sensoren mbH
Carl-Poellath-Str. 19
D-86259 Schrobenhausen
- Germany -
Tel.: +49 (0) 8252 / 8943-0
Fax.: +49 (0) 8252 / 8943-11
Email: info@sensorline.de
www.sensorline.de

President/CEO:
Fred Motzko
Register Office:
Neuburg/Donau
HRB 1468

Address:
Sensor Line – Gesellschaft für
optoelektronische Sensoren mbH
Carl-Poellath-Str. 19
D-86529 Schrobenhausen/Germany

Tel.: +49-8252-8943-0
Fax: +49-8252-8943-11
eMail: sensorline@sensorline.de
Hp: www.sensorline.de

Bank Account:
Stadtparkasse Schrobenhausen
IBAN: DE64 72151880 0000 221150
SWIFT-BIC: BYLADEM1SSH
VAT: DE 181 207 708

1. GENERAL.....	3
1.1 Function:.....	3
1.2 Features:.....	3
1.3 Dimensions:	3
2. CONNECTIONS	4
2.1 Electrical (Output header or 4 pin screw clip)	4
2.2 Connector Assembly	4
2.3 Debug Pins	4
2.4 Optical.....	4
3. OUTPUT CIRCUITS AND SIGNALS	5
3.1 Without internal output circuit	5
3.2 With internal output circuit	5
4. FITTING AND STARTING.....	6
5. SPECIFICATIONS.....	6
6. SAFETY AND WARNINGS.....	7

President/CEO:
Fred Motzko
Register Office:
Neuburg/Donau
HRB 1468

Address:
Sensor Line – Gesellschaft für
optoelektronische Sensoren mbH
Carl-Poellath-Str. 19
D-86529 Schrobenhausen/Germany

Tel.: +49-8252-8943-0
Fax: +49-8252-8943-11
eMail: sensorline@sensorline.de
Hp: www.sensorline.de

Bank Account:
Stadtparkasse Schrobenhausen
IBAN:DE64 72151880 0000 221150
SWIFT-BIC: BYLADEM1SSH
VAT: DE 181 207 708

1. General

The SL MA-310 three Channel Optical Transmittance Analyzer (OTA) is an electronic interface that operates three fiber optic load sensors. The SL MA-310 serves as the interface between the fiber optic sensor and the processing unit on system level. It should be installed in a weatherproofed road side cabinet.

1.1 Function:

The interface responds to the optical sensor signal in a dynamic (AC-coupled) manner, i.e. the electrical signal caused when a load is applied to the sensor decreases to zero as the load remains applied. At a pre-adjusted threshold, a digital trigger signal per channel is generated. This signal is automatically reset after a certain time period. These characteristics allow the SL MA-310 interface to operate without the need for adjustment.

If the interface detects an interruption in the light transmission path of any channels, it flashes a particular light for each interrupted channel. The output signals (trigger signals) are transmitted via optocouplers which behave similar to relays, allowing the use of a variety of output circuitry.

1.2 Features:

- Dynamic interface for detection of light power changes
- Optocoupler digital outputs
- Trigger output (optocoupler)
- Trigger indication LED for each channel
- Error indication LED for each channel
- Reverse power protection
- Short circuit protection optionally
- Variable output circuits suitable over jumper switches
- ROHS conform

1.3 Dimensions:

3.5" (88.9 mm) wide x 8" (203.2 mm) long x 0,06" (1.5 mm) thick

President/CEO:
Fred Motzko
Register Office:
Neuburg/Donau
HRB 1468

Address:
Sensor Line – Gesellschaft für
optoelektronische Sensoren mbH
Carl-Poellath-Str. 19
D-86529 Schrobenhausen/Germany

Tel.: +49-8252-8943-0
Fax: +49-8252-8943-11
eMail: sensorline@sensorline.de
Hp: www.sensorline.de

Bank Account:
Stadtparkasse Schrobenhausen
IBAN:DE64 72151880 0000 221150
SWIFT-BIC: BYLADEM1SSH
VAT: DE 181 207 708

2. Connections

2.1 Electrical (Output header or 4 pin screw clip)

Pin No	Signal	Description
0	12 ... 24 VDC	Supply Voltage
1	GND	Ground
2	DC Output	Output Voltage
3	GND Output	Output Ground

2.2 Connector Assembly

Pin No	Signal	Description
C1	Collector	Collector output of channel 1
E1	Emitter	Emitter output of channel 1
C2	Collector	Collector output of channel 2
E2	Emitter	Emitter output of channel 2
C3	Collector	Collector output of channel 3
E3	Emitter	Emitter output of channel 3

2.3 Debug Pins

The Board has a GND pin and each channel has for pins for debug proposal. All these outputs are optional connected to an analog output header. The four pins are:

Ax	Analog load signal of channel x
Mx	Monitor signal of channel x
Rx	Reference voltage of channel x
Tx	Trigger voltage of channel x

2.4 Optical

SMA-Connectors
(SMA series 905)

LED Transmitter, Photodetector

President/CEO: Fred Motzko
Register Office: Neuburg/Donau
 HRB 1468
Address: Sensor Line – Gesellschaft für
 optoelektronische Sensoren mbH
 Carl-Poellath-Str. 19
 D-86529 Schrobenhausen/Germany

Tel.: +49-8252-8943-0
Fax: +49-8252-8943-11
eMail: sensorline@sensorline.de
Hp: www.sensorline.de

Bank Account:
 Stadtparkasse Schrobenhausen
 IBAN:DE64 72151880 0000 221150
 SWIFT-BIC: BYLADEM1SSH
VAT: DE 181 207 708

3. Output Circuits and Signals

There are several output circuits possible:

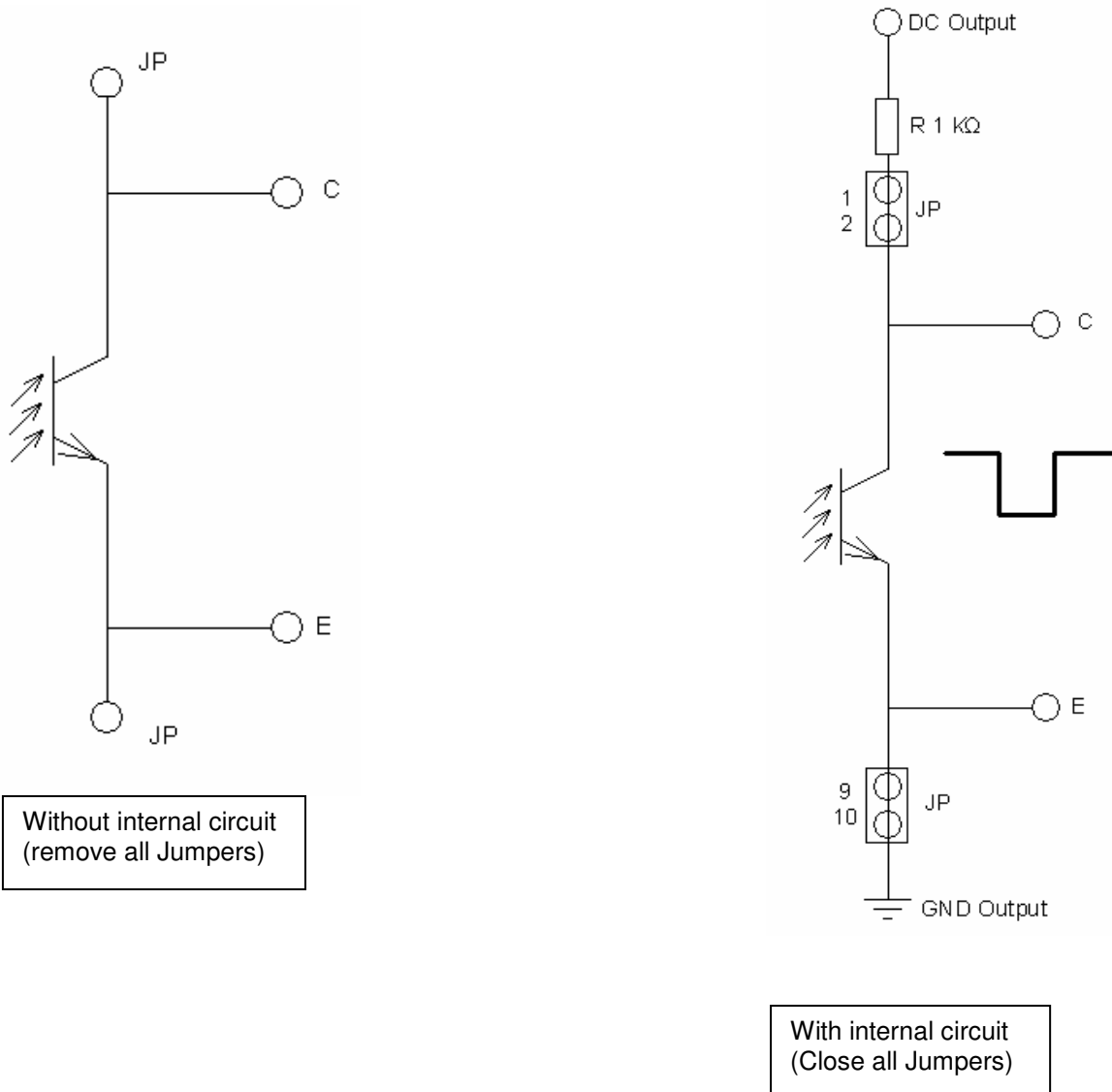

3.1 Without internal output circuit

The optocoupler outputs can be used as a simple relay. You can connect the collector and emitter of the optocoupler directly with your circuit. (Remove all Jumpers and don't connect "DC Output" and "GND Output" PIN2 and PIN3)

3.2 With internal output circuit

You can use the internal output circuit by closing the Jumper switches for each channel (e.g. Channel 1 Jumper 1/2 and 9/10 Channel 2 Jumper 3/4 and 11/12 ...). The value of the output voltage is controlled by the DC output and GND output (PIN2 and PIN3).

President/CEO: Fred Motzko
Register Office: Neuburg/Donau HRB 1468
Address: Sensor Line – Gesellschaft für optoelektronische Sensoren mbH
 Carl-Poellath-Str. 19
 D-86529 Schrobenhausen/Germany

Tel.: +49-8252-8943-0
Fax: +49-8252-8943-11
eMail: sensorline@sensorline.de
Hp: www.sensorline.de

Bank Account: Stadtparkasse Schrobenhausen
 IBAN:DE64 72151880 0000 221150
 SWIFT-BIC: BYLADEM1SSH
 VAT: DE 181 207 708

4. Fitting and starting

- 1) Fit the interface with screws. Take care that road vibrations will not influence the board and in specific the fiber optic connectors
- 2) Remove the safety caps from LED transmitter and photodetector.
- 3) Connect the sensor SMA connectors with transmitters and photodetectors of each channel. Fasten properly the sensor SMA connectors with transmitters and photodetectors in order to guarantee smallest attenuation, but do not use any pliers. The connectors of transmitters and photodetectors are allowed to be interchanged per channel.
- 4) Connect the pins 0 (Supply Voltage) and 1 (Ground) to the power supply.
- 5) Connect the signal outputs (Connector Assembly)
- 6) Turn on power supply
- 7) Test the installation by driving over the embedded sensors and monitor the Trigger signals (Trigger LEDs) or Vanalog signal (Debug Pin Ax). Test the sensor Error signal (Error LED) by disconnecting one of the fiber connectors.

5. Specifications

Supply Voltage:	+12 to +24 VDC
Supply Current (continuous):	< 400mA
Trigger Threshold:	0.3% of light transmittance change
Sensor Attenuation:	3 - 23 dB (red transmitter)
Sensor Attenuation:	3 - 33 dB (infrared transmitter)
Max. Strain Optocouplers:	60V/25mA
Velocity Range:	1 to 250 km/h
Feeder Length:	up to 250 meters
Laser Class:	3A (infrared transmitter)
Certification	ROHS

President/CEO:
Fred Motzko
Register Office:
Neuburg/Donau
HRB 1468

Address:
Sensor Line – Gesellschaft für
optoelektronische Sensoren mbH
Carl-Poellath-Str. 19
D-86529 Schrobenhausen/Germany

Tel.: +49-8252-8943-0
Fax: +49-8252-8943-11
eMail: sensorline@sensorline.de
Hp: www.sensorline.de

Bank Account:
Stadtparkasse Schrobenhausen
IBAN:DE64 72151880 0000 221150
SWIFT-BIC: BYLADEM1SSH
VAT: DE 181 207 708

6. Safety and Warnings

- Do not stare into the LED light beam with unprotected eyes.
- Only turn on power supply after connecting the sensor or with applied safety caps.
- The equipment may only be used for the considered purpose.
- The manual should be stored at hand and be delivered to every user.
- Any changes and the use of spares which are not sold by the manufacturer cause rejects of warranty.
- Repairs are only allowed to the manufacturer.

Important notice

All the information contained herein is believed to be accurate and reliable. However, SENSOR LINE assumes no responsibility for its use or for any infringements of patents or other rights of third parties that may result from its use. No license is granted by implication or otherwise under any patent rights of SENSOR LINE GmbH.

SENSOR LINE GMBH SHALL NOT BE LIABLE FOR ANY SPECIAL, INCIDENTAL, OR CONSEQUENTIAL DAMAGES RELATED TO THE USE OF THIS PRODUCT.

All rights reserved. Reproduction or adaptation of any part of this documentation beyond without permission of the Copyright owner is unlawful.

© Copyright 2006 by:



President/CEO:
Fred Motzko
Register Office:
Neuburg/Donau
HRB 1468

Address:
Sensor Line – Gesellschaft für
optoelektronische Sensoren mbH
Carl-Poellath-Str. 19
D-86529 Schrobenhausen/Germany

Tel.: +49-8252-8943-0
Fax: +49-8252-8943-11
eMail: sensorline@sensorline.de
Hp: www.sensorline.de

Bank Account:
Stadtparkasse Schrobenhausen
IBAN:DE64 72151880 0000 221150
SWIFT-BIC: BYLADEM1SSH
VAT: DE 181 207 708